



**APEX DYNAMICS**

# SMART LUBRICATION SYSTEM



# Lubrication System

## ▶ Main Features:

- CE & ATEX Certification
- Support up to 40 Lubrication Positions
- Lubrication Frequency Adjustable
- Hand-Set and PLC Control Mode
- Memory Function
- Fill Level Monitoring and Electrical Self-Protection



## About Apex Dynamics

The world is constantly changing. Also in the technical field, developments can hardly be kept up to date. In the world of automation and robotization, for example, yesterday's innovations are already commonplace today. As a result, many companies are caught between a shortage of personnel with deep substantive knowledge and a need for automation or technical innovation. How do we get the market moving forward?

Apex Dynamics supplies the essential parts for the mechanical drive of machines and robots. But that does not stop with gearboxes, racks and pinions. Apex Dynamics provides its customers and the market, where necessary, with the knowledge and expertise that will help you move forward. In addition, we take our responsibility when it comes to training new young specialists. With our innovative products, in-depth knowledge and years of experience, we do not only help the industry but also you further on a commercial and product-technical level.

We create opportunities for our customers, the technical industry and the world around us to move forward. Together we work on advanced solutions for the challenges of tomorrow. Apex Dynamics stands for a forward movement.

# Order Code of Lubricator

## LUG - 411 / 412 / 422 / 423 / 423

No. of Outlet	No. of Pump	No. of Lubrication Postions
LUG-411 : 1	LUG-411 : 1	LUG-411 : max. 4 <sup>(1)</sup> / 14 <sup>(2)</sup>
LUG-412 : 2	LUG-412 : 2	LUG-412 : max. 8 <sup>(1)</sup> / 28 <sup>(2)</sup>
LUG-422 : 2 (1+1)	LUG-422 : 2	LUG-422 : max. 8 <sup>(1)</sup> / 28 <sup>(2)</sup>
LUG-423 : 3 (2+1)	LUG-423 : 2	LUG-423 : max. 12 <sup>(1)</sup> / 42 <sup>(2)</sup>
LUG-424 : 4 (2+2)	LUG-424 : 2	LUG-424 : max. 16 <sup>(1)</sup> / 56 <sup>(2)</sup>

(1) Requiring use of a Distributor.

(2) Requiring use of a Progressive Flow Distributor.

## LUG - 2102 / 2204 / 2306 / 2408 / 2510

No. of Outlet	No. of Pump	No. of Lubrication Postions
LUG-2102 : 2	LUG-2102 : 1	LUG-2102 : max. 8
LUG-2204 : 4	LUG-2204 : 2	LUG-2204 : max. 16
LUG-2306 : 6	LUG-2306 : 3	LUG-2306 : max. 24
LUG-2408 : 8	LUG-2408 : 4	LUG-2408 : max. 32
LUG-2510 : 10	LUG-2510 : 5	LUG-2510 : max. 40



**LUG 400**



**LUG 2000**



©2018 by APEX DYNAMICS, INC.

APEX DYNAMICS, INC. reserves modification and copyrights of all technical specifications, illustrations and drawings in this catalog in allowance for continuous products development and advancement. For the newest data and information, please visit [www.apexdyna.com](http://www.apexdyna.com) or [www.apexdyna.nl](http://www.apexdyna.nl)

# Lubrication System Example of Application

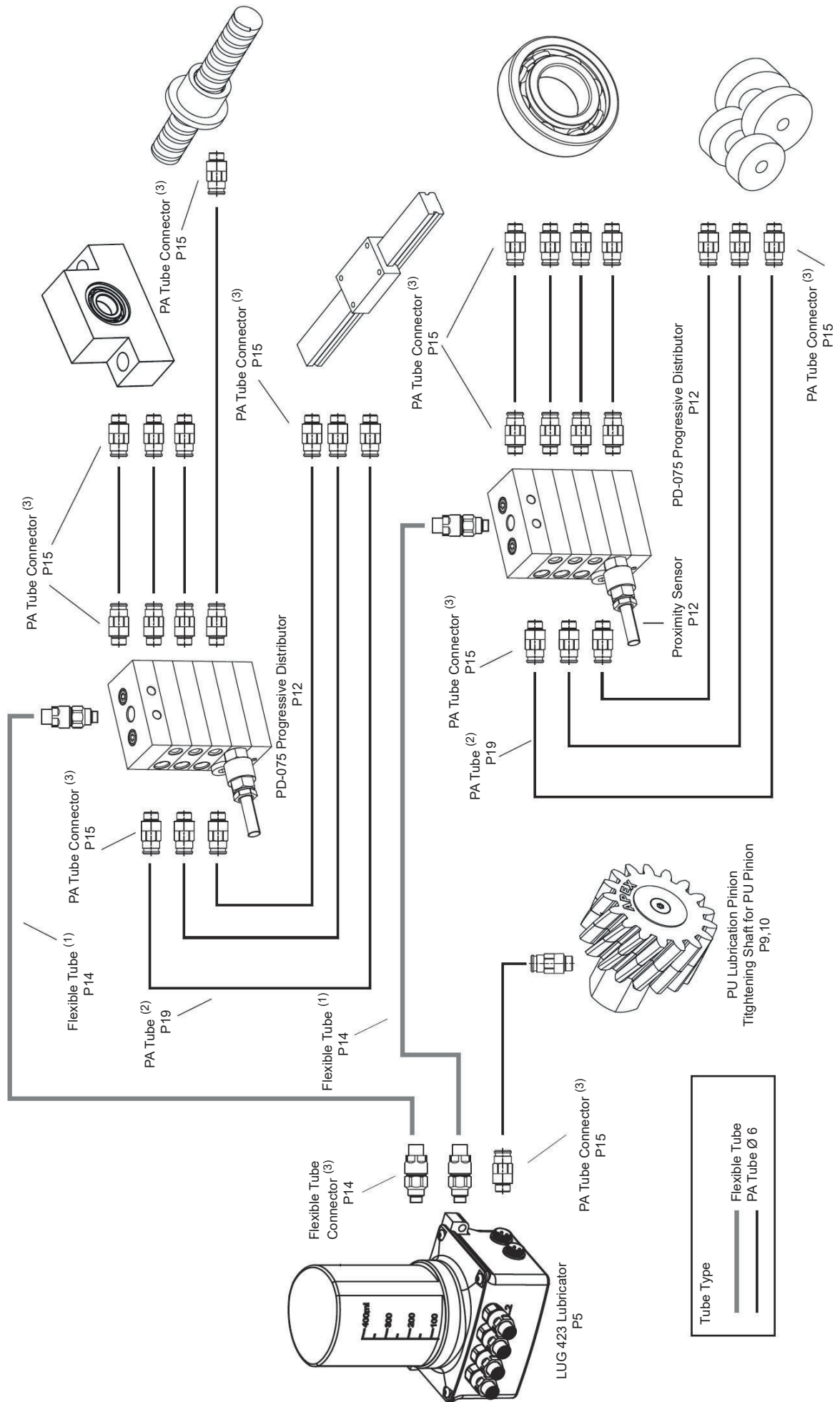

(1) Using in the main tube lubricator, the total length of 5m (inclusive) recommended PA Tube, total length > 5m recommend a flexible tube.  
 (2) Using a dispenser of the PA tube is suitable Ø4, Ø6 PA tube. When the total length of PA tube < 1m and recommended Ø4 PA tube, when the total length > 1m and recommended Ø6 PA tube.  
 (3) Both provide in-line connector option and right-angle connector option for flexible tube and PA tube.

# Performance of LUG 400

Technical Specification	
Dimensions (Width x Height x Depth)	167 mm x 196 mm x 94 mm
Weight (No Lubricant)	1780 gr.
Volume of Lubricant	400 cm <sup>3</sup>
Lubricant Type	Grease up to NLGI 3
Pump	Piston Pump
Operating Pressure	Max. 70 bar ( 1.000 psi )
Delivery Volume per Pulse / Stroke	0,15 cm <sup>3</sup>
No. of Outlet	Max. 4 Tube Connectors <sup>(1)</sup>
No. of Lubrication Position	Max. 16 <sup>(2)</sup>
Outlet Connection	PA Tube
Operating Voltage	24 VDC
Current Consumption	I <sub>max</sub> 500 mA
Connector Plug	M16 x 1,0 (5-PIN Connector)
IP Class	IP65
Operating Temperature	-25° C ~ 70° C
Control	PLC, Hand-Set Controller <sup>(3)</sup>
Pressure Monitoring	System Pressure Measurement
Oil Filling Monitoring	Reed Switch

## Lubricator

No. of Outlet	No. of Pump	No. of Lubrication Position <sup>(2)</sup>	Order Code
1	1	max. 4	LUG-411
2	1	max. 8	LUG-412
2 (1+1)	2	max. 8	LUG-422
3 (2+1)	2	max. 12	LUG-423
4 (2+2)	2	max. 16	LUG-424

(1) Connector Dimension M10.

(2) Requiring use of a Distributor.

(3) Hand-Set is not included in lubricator and is to order separately.

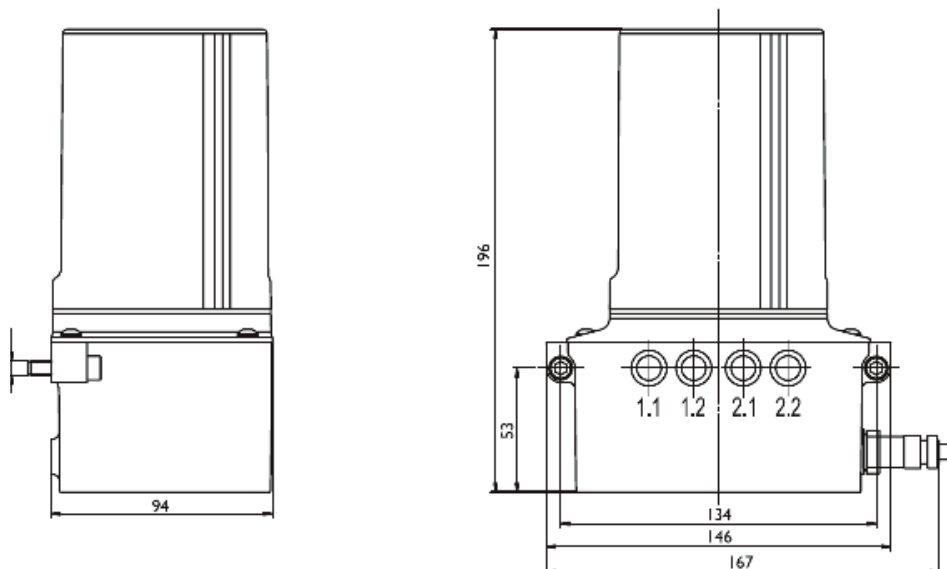



# Performance of LUG 2000

Technical Specification	
Dimensions (Width x Height x Depth)	197 mm x 286,5 mm x 175 mm
Weight (No Lubricant)	4.000 gr.
Volume of Lubricant	2.000 cm <sup>3</sup>
Lubricant Type	Oil
Pump	Piston Pump
Operating Pressure	Max. 70 bar ( 1.000 psi )
Delivery Volume per Pulse / Stroke	0,15 cm <sup>3</sup>
No. of Outlet	Max. 10 ( In-Line Connector ) <sup>(1)</sup>
No. of Lubrication Position	Max. 40 <sup>(2)</sup>
Outlet Connection	PA Tube
Operating Voltage	24 VDC
Current Consumption	I <sub>max</sub> ≤ 500 mA
Connector Plug	M16 x 1,0 (5-PIN Connector)
IP Class	IP65
Operating Temperature	-25° C ~ 70° C
Control	PLC, Hand-Set Controller <sup>(3)</sup>
Pressure Monitoring	System Pressure Measurement
Oil Filling Monitoring	Reed Switch

## Lubricator

No. of Outlet	No. of Pump	No. of Lubrication Position <sup>(2)</sup>	Order Code
2	1	max. 8	LUG-2102
4	2	max. 16	LUG-2204
6	3	max. 24	LUG-2306
8	4	max. 32	LUG-2408
10	5	max. 40	LUG-2510

(1) Connector Dimension M10.

(2) Requiring use of a Distributor.

(3) Hand-Set is not included in lubricator and is to order separately.

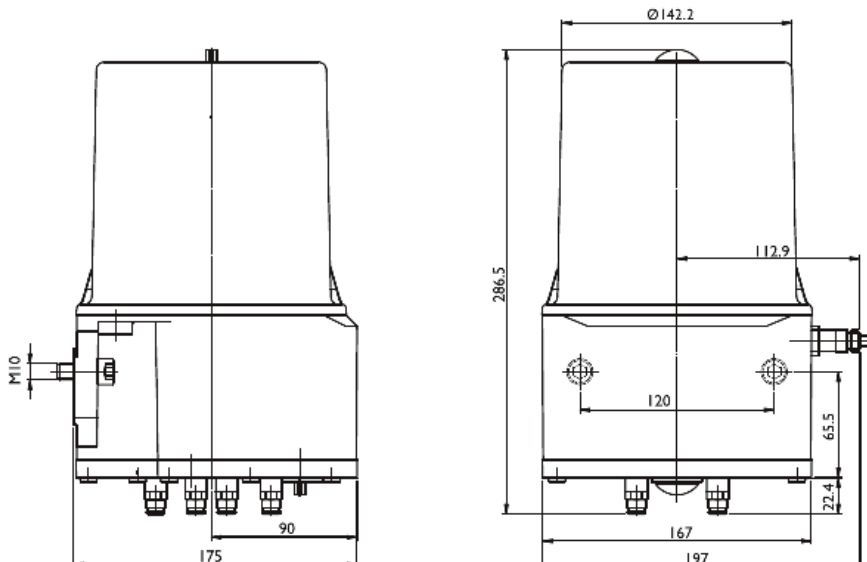

# Power System

- 24 V DC is applied to the Lubricator. Any electrical interference during power connection should be avoided.

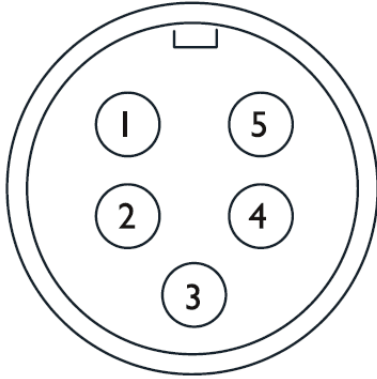

5-Pin Socket

The connection between lubricator and controller via 5-Pin Socket

PIN 1 : Output Signal  
 PIN 2 : Input Signal  
 PIN 3 : FGND  
 PIN 4 : Input 24 V DC  
 PIN 5 : GND

- Hand-Set Controller (Order Code : EC01).

After set-up of lubricator, the Hand-Set Controller can be removed.  
 Please also refer to Manual of Installation.

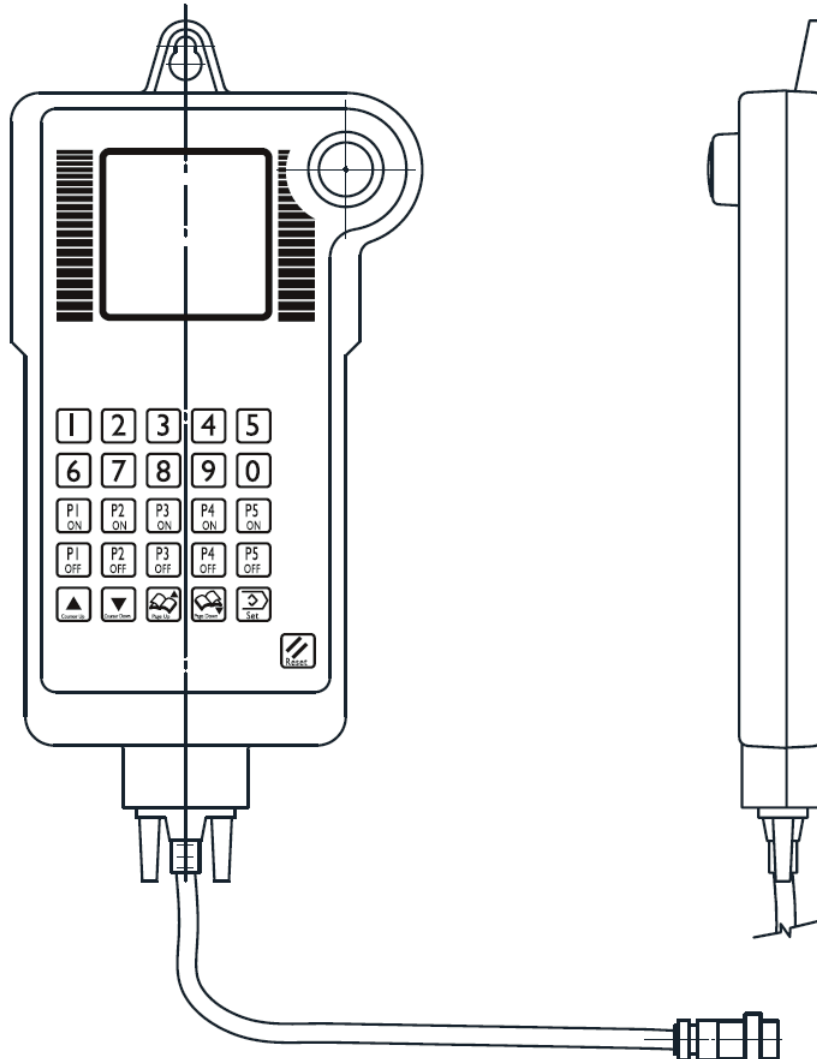

# Lubrication of Rack & Pinion

- As transmission devices, Rack and Pinion are often exposed to air and may oxidized. It's highly recommended to use APEX PU Lubrication Pinion to perform greasing and uniform distribution of lubricant on all teeth surfaces.
- Open-Cell Polyurethane Foam of PU Lubrication Pinion can absorb a certain amount of lubricant. Standard Involute Teeth Design can fit perfectly the teeth of Rack and Pinion without any loading by lubrication. Under long-time operation condition, PU Lubrication Pinion provides an automatic lubrication process on transmission devices to reduce wearing, but no over-lubrication.
- First soak PU Lubrication Pinion in lubricant to allow an immediate application. The Feeding Rate of lubricate depends on Module No. and Speed, can be adjusted by controller. Please also refer to table 1 below showing Lubricant Volume vs. Module No..

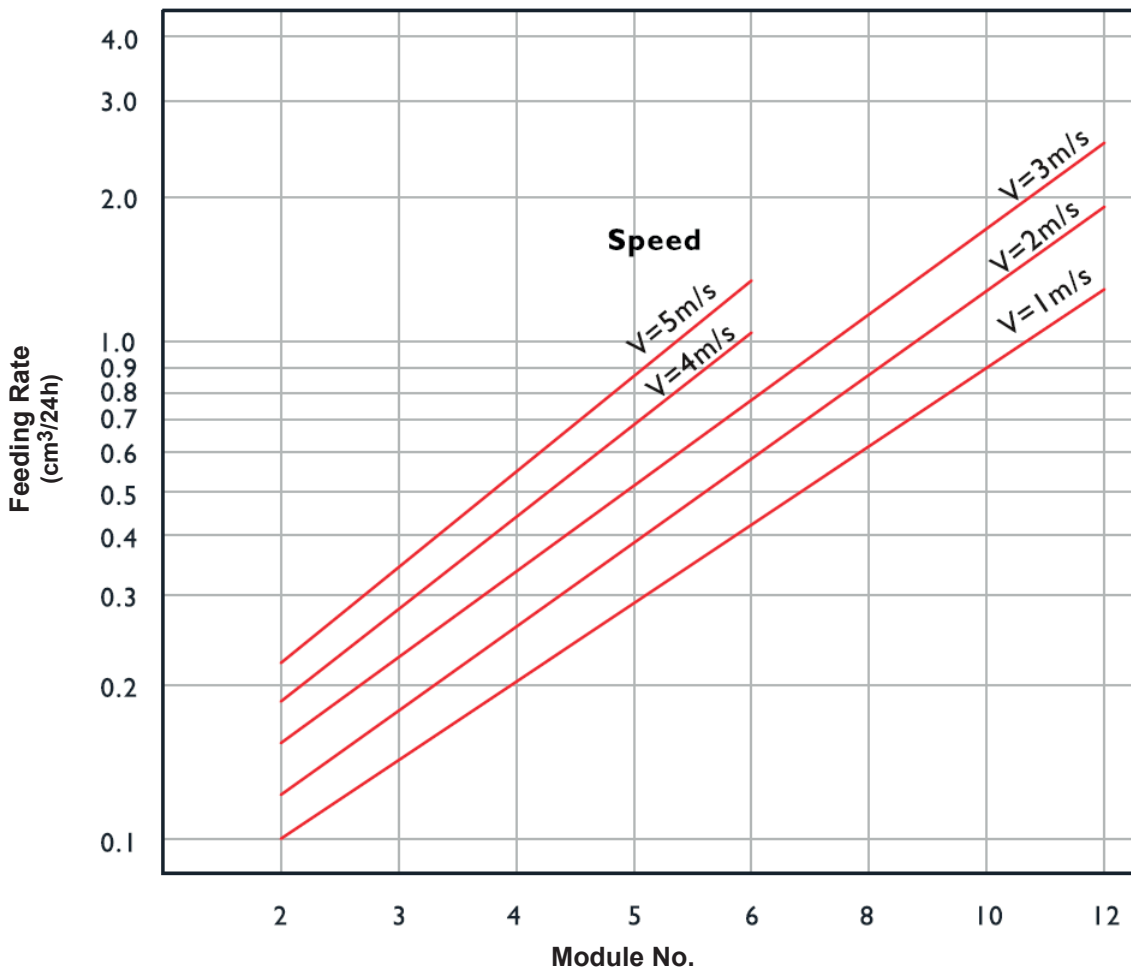
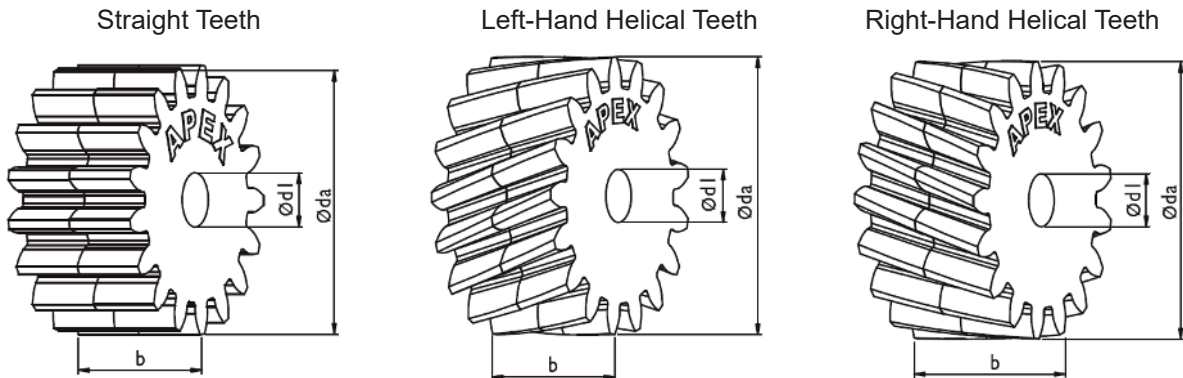

Table 1



# PU Lubrication Pinion

- Effective Lubrication can be achieved through the use of APEX Lubrication System especially for Rack and Pinion. For uniform distribution of lubricant over rack surface, it's recommended to use a driving Pinion to allow evenly greasing.



Module No.	Z (1)	Application	da (2)	dF (3)	dl	b	Order Code	Central Height a
1	36	Straight Teeth	38	36	12	15	PU-01-36S	$a = \frac{d + dF}{2} \quad (4)$ $A = h_0 + \frac{df}{2} \quad (5)$
		Rack ( Left-Hand Helical )	40,2	38,2			PU-01-36L	
		Pinion ( Right-Hand Helical )	40,2	38,2			PU-01-36R	
1,5	24	Straight Teeth	39	36	12	20	PU-1J-24S	
		Rack ( Left-Hand Helical )	41,2	38,2			PU-1J-24L	
		Pinion ( Right-Hand Helical )	41,2	38,2			PU-1J-24R	
2	17	Straight Teeth	38	34	2	25	PU-02-17S	
		Rack ( Left-Hand Helical )	40,1	36,1			PU-02-17L	
		Pinion ( Right-Hand Helical )	40,1	36,1			PU-02-17R	
2,5	17	Straight Teeth	47,5	42,5	12	25	PU-2J-17S	
		Rack ( Left-Hand Helical )	50,1	45,1			PU-2J-17L	
		Pinion ( Right-Hand Helical )	50,1	45,1			PU-2J-17R	
3	17	Straight Teeth	57	51	12	30	PU-03-17S	
		Rack ( Left-Hand Helical )	60,1	54,1			PU-03-17L	
		Pinion ( Right-Hand Helical )	60,1	54,1			PU-03-17R	
4	17	Straight Teeth	76	68	12	40	PU-04-17S	
		Rack ( Left-Hand Helical )	80,2	72,2			PU-04-17L	
		Pinion ( Right-Hand Helical )	80,2	72,2			PU-04-17R	
5	17	Straight Teeth	95	85	20	50	PU-05-17S	
		Rack ( Left-Hand Helical )	100,2	90,2			PU-05-17L	
		Pinion ( Right-Hand Helical )	100,2	90,2			PU-05-17R	
6	17	Straight Teeth	114	102	20	60	PU-06-17S	
		Rack ( Left-Hand Helical )	120,2	108,2			PU-06-17L	
		Pinion ( Right-Hand Helical )	120,2	108,2			PU-06-17R	
8	17	Straight Teeth	152	136	20	80	PU-08-17S	
		Rack ( Left-Hand Helical )	160,3	144,3			PU-08-17R	
		Pinion ( Right-Hand Helical )	16,3	144,3			PU-08-17S	
10	17	Straight Teeth	190	170	20	100	PU-10-17S	
		Rack ( Left-Hand Helical )	200,4	180,4			PU-10-17R	
		Pinion ( Right-Hand Helical )	200,4	180,4			PU-10-17S	
12	14	Straight Teeth	192	168	25	120	PU-12-14S	
		Rack ( Left-Hand Helical )	202,3	178,3			PU-12-14L	
		Pinion ( Right-Hand Helical )	202,3	178,3			PU-12-14R	
1,591 (Pt 5)	24	Straight Teeth	41,4	38,2	12	20	PU-1K-24S	
3,183 (Pt 10)	17	Straight Teeth	60,5	54,1	12	30	PU-3B-17S	
4,244 (Pt 13,33)	17	Straight Teeth	80,6	72,1	12	40	PU-4D-17S	

- (1) No. of Teeth (2) Tip Diameter (3) Pitch Diameter (4) Central Distance between PU Pinion ( $d$  = Pinion Pitch Diameter)  
(5) Central Distance between PU Pinion and Rack Bottom ( $h_0$  = Height between Rack's pitch line to bottom)

# Tightening Shaft for PU Pinion

## ■ Tightening Shaft ( Right-Angle )

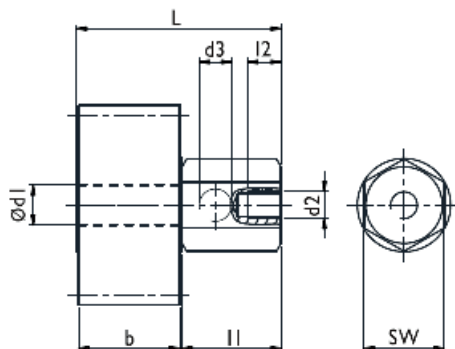

Module No.	L	l1	l2	b	dl	d2	Hole d3	SW	Order Code
1	46,4	30	10	15	12	M8	G 1/8"	24	AUX-01-1
1,5	54,4	30	10	20	12	M8	G 1/8"	24	AUX-1J-1
2	56,4	30	10	25	12	M8	G 1/8"	24	AUX-02-1
2,5	56,4	30	10	25	12	M8	G 1/8"	24	
3	61,4	30	10	30	12	M8	G 1/8"	24	AUX-03-1
4	71,4	30	10	40	12	M8	G 1/8"	24	AUX-04-1
5	81,4	30	10	50	20	M8	G 1/8"	24	AUX-05-1
6	91,4	30	10	60	20	M8	G 1/8"	24	AUX-06-1
8	111,4	30	10	80	20	M8	G 1/8"	24	AUX-08-1
10	311,4	30	10	100	20	M8	G 1/8"	24	AUX-10-1
12	152	30	10	120	25	M8	G 1/8"	30	AUX-12-1
1,591 ( Pt 5 )	51,4	30	10	20	12	M8	G 1/8"	24	AUX-1J-1
3,183 ( Pt 10 )	61,4	30	10	30	12	M8	G 1/8"	24	AUX--03-1
4,244 ( Pt 13,33 )	71,4	30	10	40	12	M8	G 1/8"	24	AUX-04-1

## ■ Tightening Shaft ( In-Line )

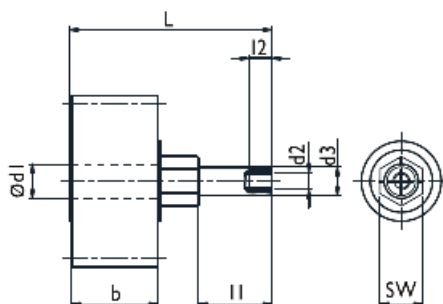

Module No,	L	l1	l2	b	dl	Hole d2	d3	SW	Order Code
1	56	30	12	15	12	M6	M10	17	AUX-01-2
1,5	61	30	12	20	12	M6	M10	17	AUX-1J-2
2	66	30	12	25	12	M6	M10	17	AUX-02-2
2,5	66	30	12	25	12	M6	M10	17	
3	71	30	12	30	12	M6	M10	17	AUX-03-2
4	81	30	12	40	12	M6	M10	17	AUX-04-2
5	116	49	12	50	20	G 1/8"	M16	24	AUX-05-2
6	126	49	12	60	20	G 1/8"	M16	24	AUX-06-2
8	146	49	12	80	20	G 1/8"	M16	24	AUX-08-2
10	166	49	12	100	20	G 1/8"	M16	24	AUX-10-2
12	186,6	49	12	120	25	G 1/8"	M16	24	AUX-12-2
1,591 ( Pt 5 )	61	30	12	20	12	M6	M10	17	AUX-1J-2
3,183 ( Pt 10 )	71	30	12	30	12	M6	M10	17	AUX--03-2
4,244 ( Pt 13,33 )	81	30	12	40	12	M6	M10	17	AUX-04-2

# Distributor

■ Distributor supports up to 4 lubrication positions. Remark for operation:

- The distance between Distributor and Lubricator outlet should be kept as short as possible.
- Install only one distributor at outlet, do not connect distributors in series.
- The pressure difference between all lubrication outlets should not exceed 8 bar.
- To use PA tube with same cross-section and similar length.

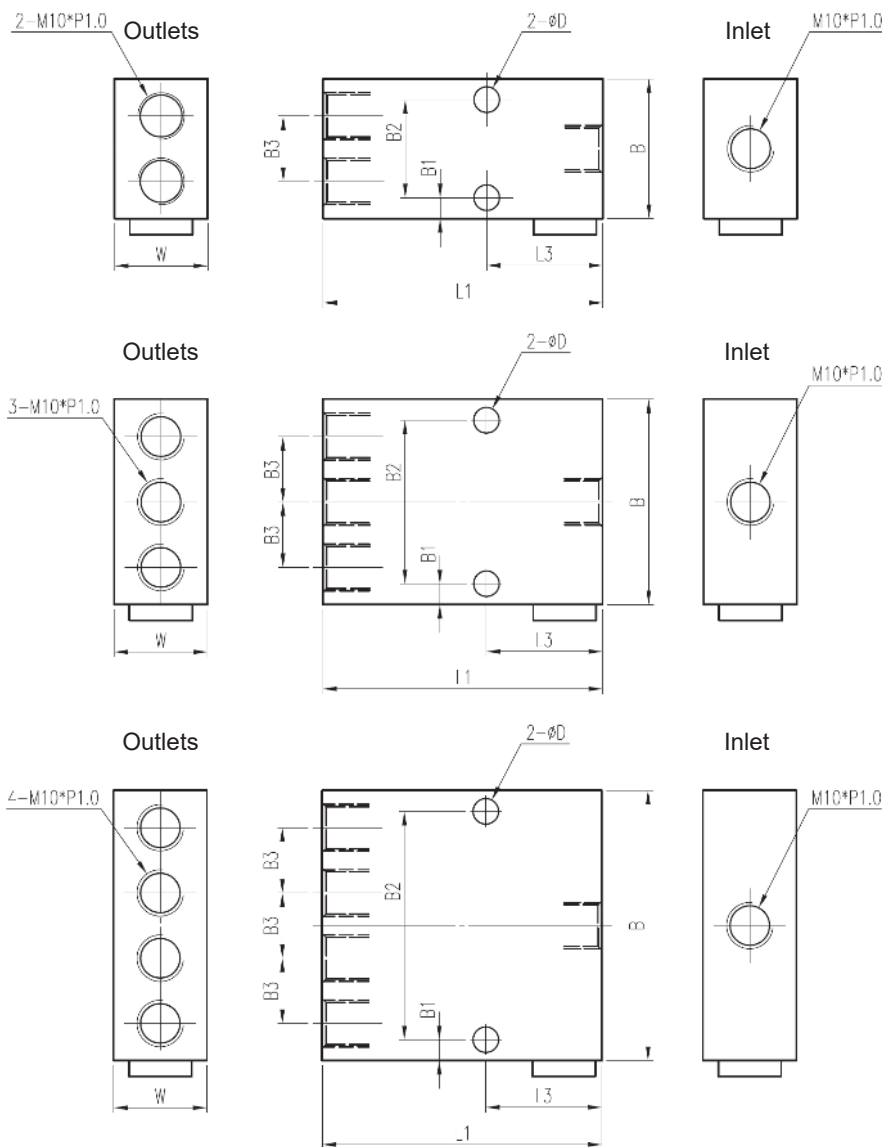

No. of Inlet	No. of Outlet	L1	L3	B	B1	B2	B3	D	W	Order Code			
										Aluminum Alloy		Stainless	
										Grease	Oil	Grease	Oil
1	2	60	24,9	30	4,5	21	14	5,5	20	SPL-602	SPL-612	SPLS-602	SPLS-612
1	3	60	24,9	44	4,5	35	14	5,5	20	SPL-603	SPL-613	SPLS-603	SPLS-613
1	4	60	24,9	58	4,5	49	14	5,5	20	SPL-604	SPL-614	SPLS-604	SPLS-614
1	2	60	24,9	32	4,5	23	16	5,5	20	SPL-802	SPL-812	SPLS-802	SPLS-812
1	3	60	24,9	48	4,5	39	16	5,5	20	SPL-803	SPL-813	SPLS-803	SPLS-813
1	4	60	24,9	64	4,5	55	16	5,5	20	SPL-804	SPL-814	SPLS-804	SPLS-814

Accordinging to required diameter, choose connector. (E.g.: SPLS-8 Series is to select for Pipe diameter 8 mm)  
 Support standard grease NLG1 2.  
 Temperature range : +10°C ~ +60°C  
 Pressure difference of outlets may result in different grease delivery volume.

# Progressive Flow Distributor

Progressive flow distributor supports multiple lubrication positions successive in the pumping cycle.

The output volume by each outlet is 0.15ml.

- Grease is to be apply.
- Supporting max 14 outlets
- Supporting Ø4 and Ø6 in-line and right-angle connector
- To use PA tube with same cross-section and similar length.

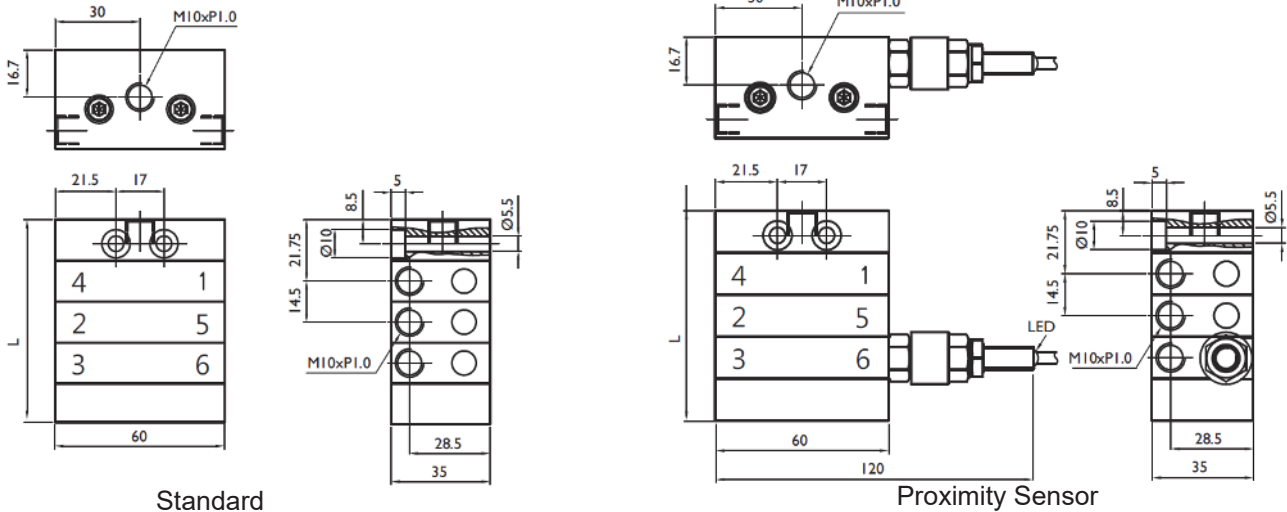

No. of Outlet	Per Stroke (ml)	Number of time for each cycle	L	Order Code	
				Standard	w. Proximity Sensor
5	0,15	5	72,5	PD-05	PD-05S
6		6	72,5	PD-06	PD-06S
7		7	87	PD-07	PD-07S
8		8	87	PD-08	PD-08S
9		9	101,5	PD-09	PD-09S
10		10	101,5	PD-10	PD-10S
11		11	16	PD-11	PD-11S
12		12	116	PD-12	PD-12S
13		13	130,5	PD-13	PD-13S
14		14	130,5	PD-14	PD-14S

- (A) Supporting standard grease NLGI 1 & 2 (B)Temperature range +10°C ~ +60°C (C)Addition proximity sensor, monitoring lubrication system is available. (D)To make sure entire pipe line should be full filled with grease for a correct function. (E) If one outlet of distributor is blocked, the successive pumping cycle is not valid.

## Proximity Sensor Technical Specification

Contact Diagram 	Brown	Operating Voltage: 10~30VDC
	Black	Output Current:150mA max.
	Blue	GND
Circuit Diagram		
Output Method		PNP
Output Status		NO
IP Degree		IP67
Order Code		Proximity Sensor : PS-01
		Proximity Sensor Connect Cable : PSL-01

The sensor lights up when a pumping cycle of the progressive distributor has been done.

# Fixing Socket

■ 5 different types of fixing socket for LUG 400.

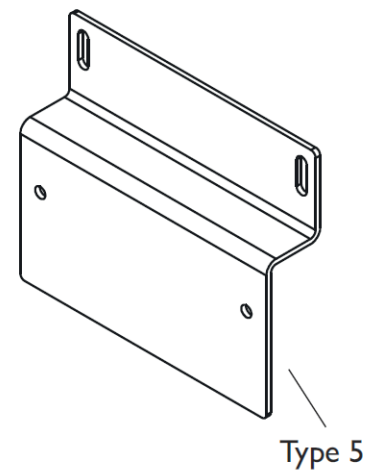
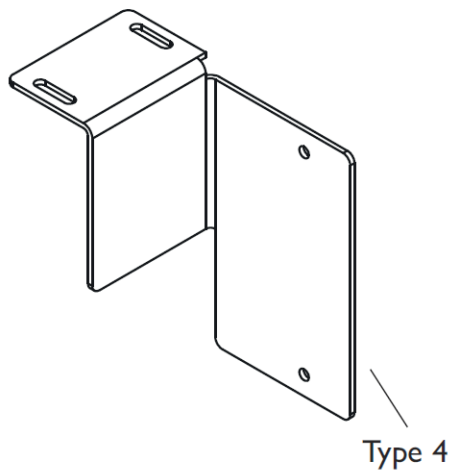
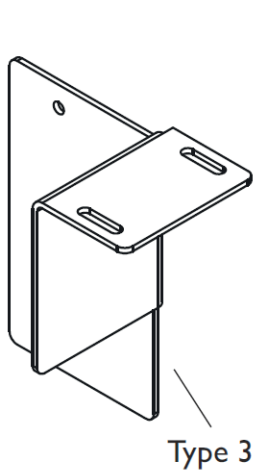
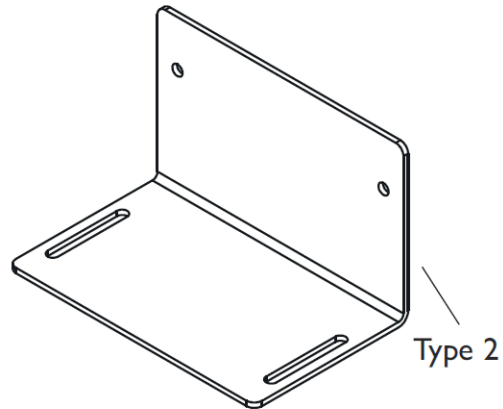
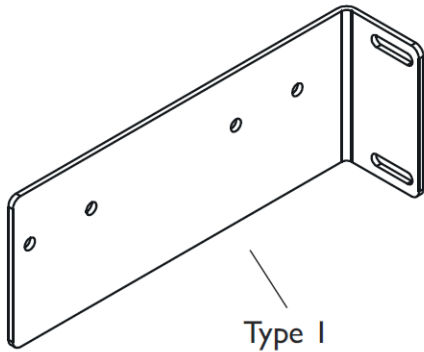

Specification	Order Code
Type 1	BK-01
Type 2	BK-02
Type 3	BK-03
Type 4	BK-04
Type 5	BK-05

- Material : SPCC
- Surface Treatment : Black flat paint
- The drawing for fixing socket support please contact with APEX

# Flexible Tube Set

■ To used for main lubrication pipe line. The spring is protecting tube, preventing the pipe line expansion due to high pressure and influence of pumping of grease.

- The max length about 15 meter
- The max permitted pressure 100 bar
- Spring is coated with nickel plated and corrosion resistance.
- Operating temperature -30°C~+80°C

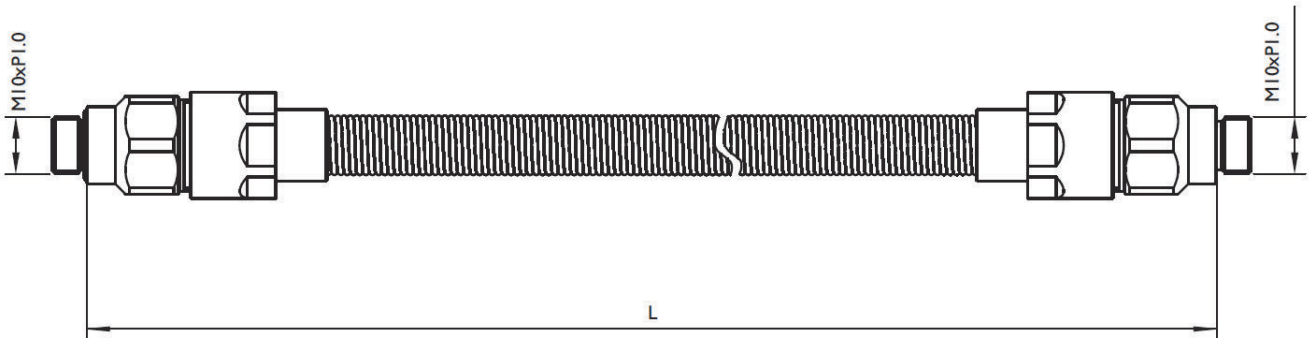

Length (meter)	Order Code
Approx. 10	FTS08-1000
Approx. 15	FTS08-1500

## Accessories

■ In-Line Connector (Material : Copper)

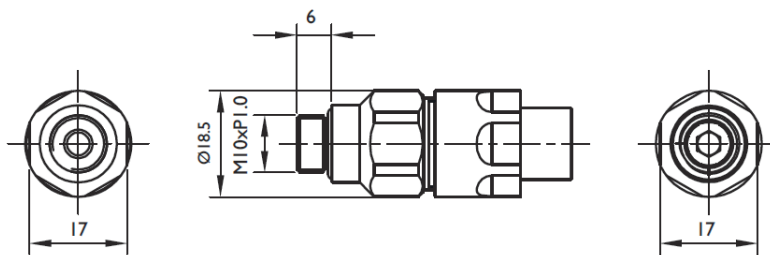

Length (meter)	Order Code
Approx. 10	FTC08-01
Approx. 15	FTC08-02

■ Protective Tube Spring (Material : Spring Steel, Surface Treatment : Nickel)

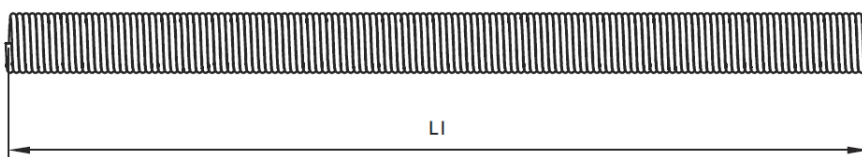

Length (meter)	L1 (meter)	Order Code
Applicable Length 10	10	PTS08-1000
Applicable Length 15	15	PTS08-1500



# Accessoires

## ■ Right-Angle Connector (Material : Copper)

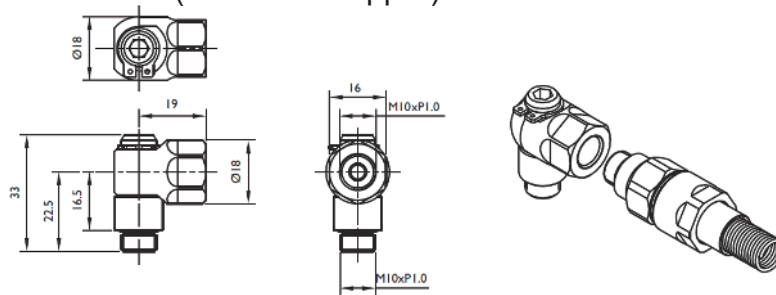

**Order Code**

R-FTC08-01

## ■ In-Line Connector

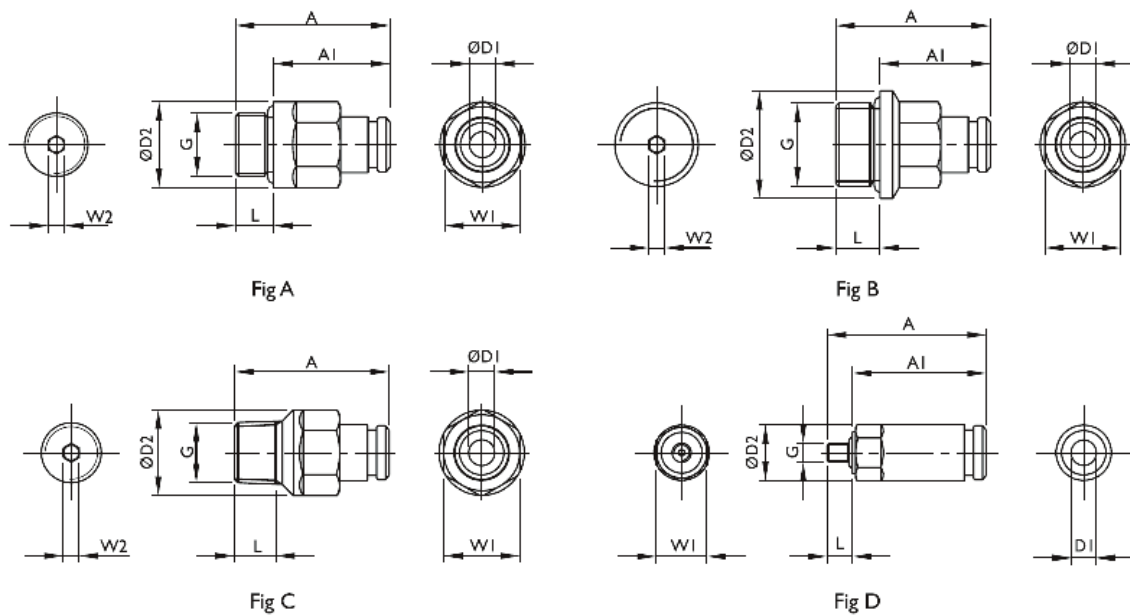

D1	D2	A	A1	G	L	W1	W2	Fig	Order Code	
									Copper	Stainless
4	8,8	25,1	21,1	M3 x 0,5	4	8	-	D	TB-401 <sup>(1)</sup>	TBS-401
4	11,5	26,1	21,1	M5 x 0,8	5	10	-	A	TB-402 <sup>(1)</sup>	TBS-402
4	11,5	26,1	21,1	M6 x 0,75	5	10	2,5	A	TB-403	TBS-403
4	11,5	26,1	21,1	M6 x 1,0	5	10	2,5	A	TB-404	TBS-404
4	11,5	24,4	18,4	M8 x 1,0	6	10	2,5	A	TB-405	TBS-405
4	13,5	24,4	18,4	M10 x 1,0	6	12	2,5	A	TB-406	TBS-406
4	13,5	24,4	18,4	G 1/8"	6	12	2,5	A	TB-407	TBS-407
6	13,5	30,1	25,1	M5 x 0,8	5	12	-	A	TB-601 <sup>(1)</sup>	TBS-601
6	13,5	30,1	25,1	M6 x 0,75	5	12	3	A	TB-602	TBS-602
6	13,5	30,1	25,1	M6 x 1,0	5	12	3	A	TB-603	TBS-603
6	13,5	30,9	24,9	M8 x 1,0	6	12	4	A	TB-604	TBS-604
6	13,5	28,4	22,4	M10 x 1,0	6	12	4	A	TB-605	TBS-605
6	13,5	28,4	22,4	G 1/8"	6	12	4	A	TB-606	TBS-606
6	17	29,4	22,4	G 1/4"	7	12	4	B	TB-607	TBS-607
6	13,5	29,9	-	R 1/8"	6,5	12	4	C	TB-608	TBS-608
8	15,2	33,3	27,3	M10 x 1,0	6	14	5	A	TB-801	TBS-801
8	15,2	33,3	27,3	G 1/8"	6	14	5	A	TB-802	TBS-802
8	17	33,3	27,3	G 1/4"	7	14	5	B	TB-803	TBS-803

(1) Material : Carbon Steel (Nickel-Plating)  
 Operation Pressure : max. 80 bar  
 Operation Temperature : -30°C ~ +100°C

# Connector

## ■ Right-Angle Connector

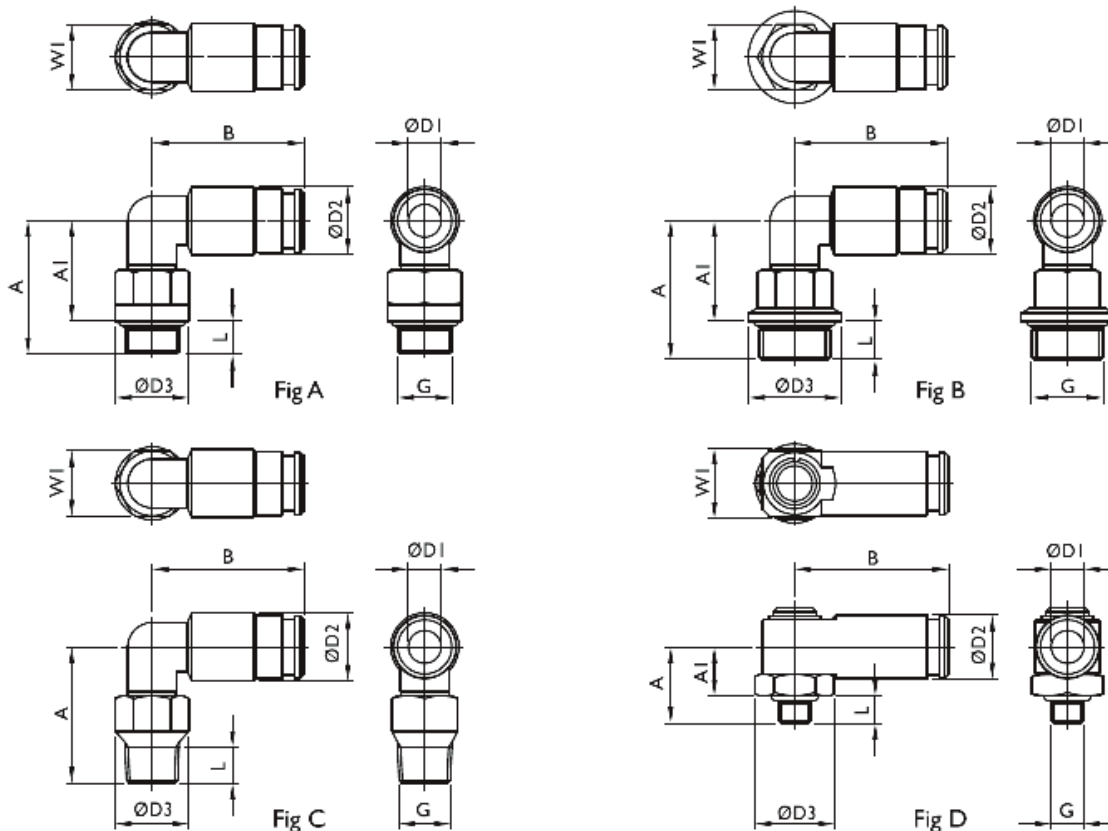

D1	D2	D3	A	A1	B	G	L	W1	Fig	Order Code	
										Copper	Stainless
4	10	11,5	18,7	14,7	22,4	M3 x 0,5	4	10	A	R-TB-401 <sup>(1)</sup>	R-TBS-401
4	10	11,5	20,7	15,7	22,4	M5 x 0,8	5	10	A	R-TB-402 <sup>(1)</sup>	R-TBS-402
4	10	11,5	20,7	15,7	22,4	M6 x 0,75	5	10	A	R-TB-403	R-TBS-403
4	10	11,5	20,7	15,7	22,4	M6 x 1,0	5	10	A	R-TB-404	R-TBS-404
4	10	13,5	23,2	17,2	22,4	M8 x 1,0	6	12	A	R-TB-405	R-TBS-405
4	10	13,5	24,2	18,2	22,4	M10 x 1,0	6	12	A	R-TB-406	R-TBS-406
4	10	13,5	24,2	18,2	22,4	G 1/8"	6	12	A	R-TB-407	R-TBS-407
4	8,8	14,5	14	9	24,2	M6 x 1,0	5	13	D	R-TB-408	R-TBS-408
4	8,8	14,5	15	9	24,2	M8 x 1,0	6	13	D	R-TB-409	R-TBS-409
4	8,8	14,5	17,5	9	24,2	R 1/8"	8,5	13	D	R-TB-410	R-TBS-410
6	12,5	11,5	21	16	27,9	M5 x 0,8	5	10	A	R-TB-601	R-TBS-601
6	12,5	11,5	21	16	27,9	M6 x 0,75	5	10	A	R-TB-602	R-TBS-602
6	12,5	11,5	21	16	27,9	M6 x 1,0	5	10	A	R-TB-603	R-TBS-603
6	12,5	13,5	23,5	17,5	27,9	M8 x 1,0	6	12	A	R-TB-604	R-TBS-604
6	12,5	13,5	24,5	18,5	27,9	M10 x 1,0	6	12	A	R-TB-605	R-TBS-605
6	12,5	13,5	24,5	18,5	27,9	G 1/8"	6	12	A	R-TB-606	R-TBS-606
6	12,5	17	25,5	18,5	27,9	G 1/4"	7	12	B	R-TB-607	R-TBS-607
6	12,5	13,5	25	-	27,9	R 1/8"	6,5	12	C	R-TB-608	R-TBS-608
6	11,7	14,5	14	9	28,2	M6 x 1,0	5	13	D	R-TB-609	R-TBS-609
6	11,7	14,5	15	9	28,2	M8 x 1,0	7	13	D	R-TB-610	R-TBS-610
6	11,7	14,5	17,5	9	28,2	R 1/8"	8,5	13	D	R-TB-611	R-TBS-611
8	14,5	14,5	25,5	19,5	29,8	M10 x 1,2	6	13	A	R-TB-801	R-TBS-801
8	14,5	14,5	25,5	19,5	29,8	G 1/8"	6	13	A	R-TB-802	R-TBS-802
8	14,5	17	25,5	19,5	29,8	G 1/4"	7	13	B	R-TB-803	R-TBS-803

(1) Material : Carbon Steel (Nickel-Plating)  
 Operation Pressure : max. 80 bar  
 Operation Temperature -30°C ~ +100°C

# Connector

## ■ Tube Connector

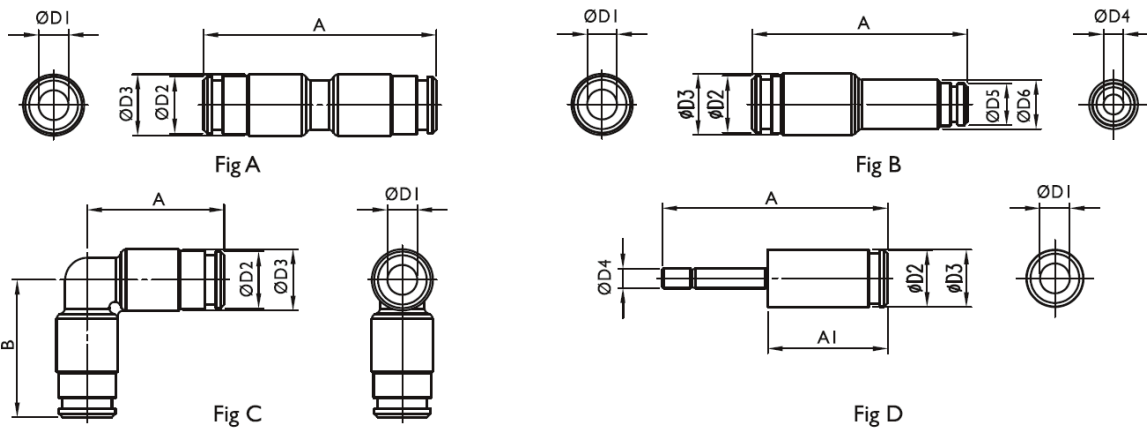

D1	D2	D3	D4	D5	D6	A	A1	B	Fig	Order Code	
										Copper	Stainless
4	8,5	10,0	-	-	-	39,8	-	-	A	C-TB-401	C-TBS-401
4	8,5	10,0	-	-	-	22,4	-	22,4	C	C-TB-402	C-TBS-402
4	8,5	8,8	6	-	-	45,4	20,4	-	D	C-TB-403	C-TBS-403
6	11,5	12,5	-	-	-	47,8	-	-	A	C-TB-601	C-TBS-601
6	11,5	12,5	4	8,5	10	43,8	-	-	B	C-TB-602	C-TBS-602
6	11,5	12,5	-	-	-	27,9	-	27,9	C	C-TB-603	C-TBS-603
6	11,5	11,7	4	-	-	45,9	24,4	-	D	C-TB-604	C-TBS-604
8	13,5	15	6	11,5	12,5	49,2	-	-	B	C-TB-801	C-TBS-801
8	13,5	13,8	6	-	-	51,3	26,3	-	D	C-TB-802	C-TBS-802

## ■ Right-Angle Non-Return Valve

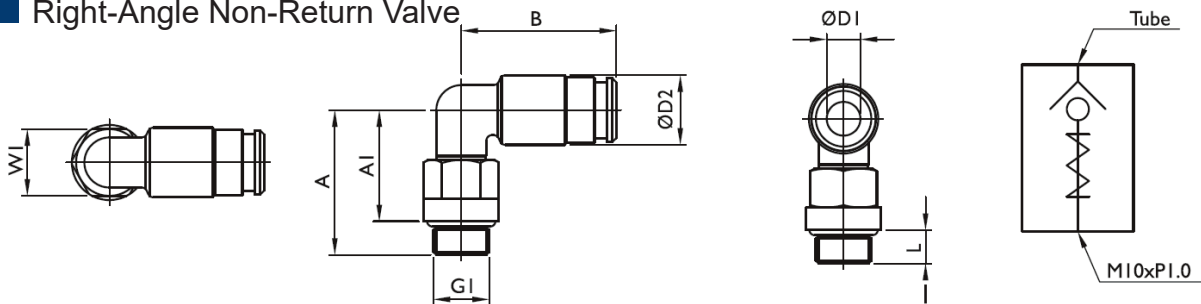

D1	D2	A	A1	B	G1	L	W1	Order Code	
								Copper	Stainless
4	10	24,2	18,2	22,4	M1 x 1,0	6	12	RV-TB-401	RV-TBS-401
6	12,5	26	20	27,9	M1 x 1,0	6	12	RV-TB-402	RV-TBS-402
8	14,5	27	21	29,8	M1 x 1,0	6	13	RV-TB-403	RV-TBS-403

Function of Non-Return Valve : Avoid of backflow, Resistance of pressure.

## ■ Oil Filling Connector

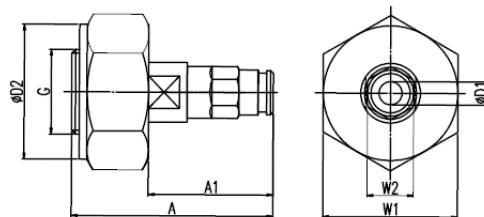

D1	D2	A	A1	G	W1	W2	Order Code
4	35	48,4	28,4	M22 x 2,0	35	12	TB-4-22
6	35	52,4	32,4	M22 x 2,0	35	12	TB-6-22
8	35	57,3	37,3	M22 x 2,0	35	14	TB-8-22

The oil filling connector is to apply for refilling of lubricant.

High kinematic viscosity of lubricant will reduce the pumping distence to the device or facility.

Pay attention to kinematic viscosity by refilling of Non-APEX lubricant.

# Lubricator Cartridge

## ■ Empty Cartridge ( Order Code : G00 )

For Self-Filling of Grease.

Oil Filling Connector is necessary.

Support LUG-400 Lubricator.

## ■ Standard Grease ( Order Code : G01 )

NLGI Grade 2

Temperature Range -30°C ~ +140°C.

Containing PTFE, good performance in high pressure and metal adhesion.

Suitable for high loading gear transmission system.

Suitable for high temperature environment.

Kinematic Viscosity 32 cSt / 40°C

Supports LUG Lubricator pre-fill at 400 cm<sup>3</sup>

## ■ Food Grade Grease ( Order Code : G02 )

NLGI Grade 2

Temperature Range -35°C ~ +120°C.

NFS H1 livense.

Provide good wearing resistance and extend lubrication interval.

Food Grade Grease is Non-toxic, Odorless, Colorless and tasteless.

Kinematic Viscosity 50 cSt / 40°C

Supports LUG Lubricator pre-fill at 400 cm<sup>3</sup>

## ■ Low Temperature Grease ( Order Code : G03 )

NLGI Grade 2

Temperature Range -50°C ~ +120°C.

Contains special additives for anti-wear, anti-oxidant, anti-corrosion and high pressure resistance.

Suitable for high loading gear transmission system.

Kinematic Viscosity 15 cSt / 40°C

Supports LUG Lubricator pre-fill at 400 cm<sup>3</sup>

### Remark

The APEX Smart Lubricant System has been optimized for the 3 greases as shown above.

Using other greases, the pumping performance of APEX Lubrication System could be different.

# PA Tube (Poly-Amide)

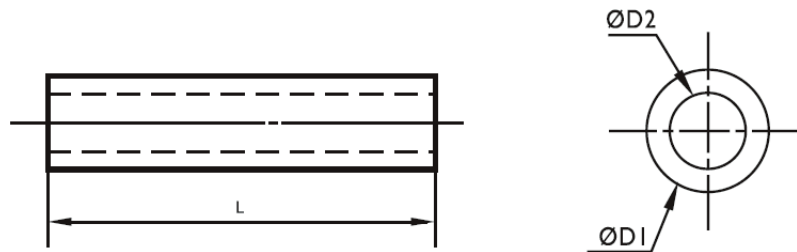

Type of Grease	D1	D2	Length in Package (meter)	Order Code
Empty Tube	4	2,5	200	T04
	6	4	200	T06
	8	5	100	T08
Standard Grease ( Order Code : G01 )	4	2,5	5	T04-01
	6	4	10	T06-01
	8	5	10	T08-01
Food Grade ( Order Code : G02 )	4	2,5	5	T04-02
	6	4	5	T06-02
	8	5	5	T08-02
Low Temperature ( Order Code : G03 )	4	2,5	5	T04-03
	6	4	10	T06-03
	8	5	10	T08-03

PA 12 Tube is pre-filled with grease

Operation Pressure : 25 kg/cm<sup>2</sup> by 4 mm PA Tube; 28 kg/cm<sup>2</sup> by 6mm & 8mm PA Tube (Temperature 20°C)

Operation Temperature : -40°C ~ +80°C

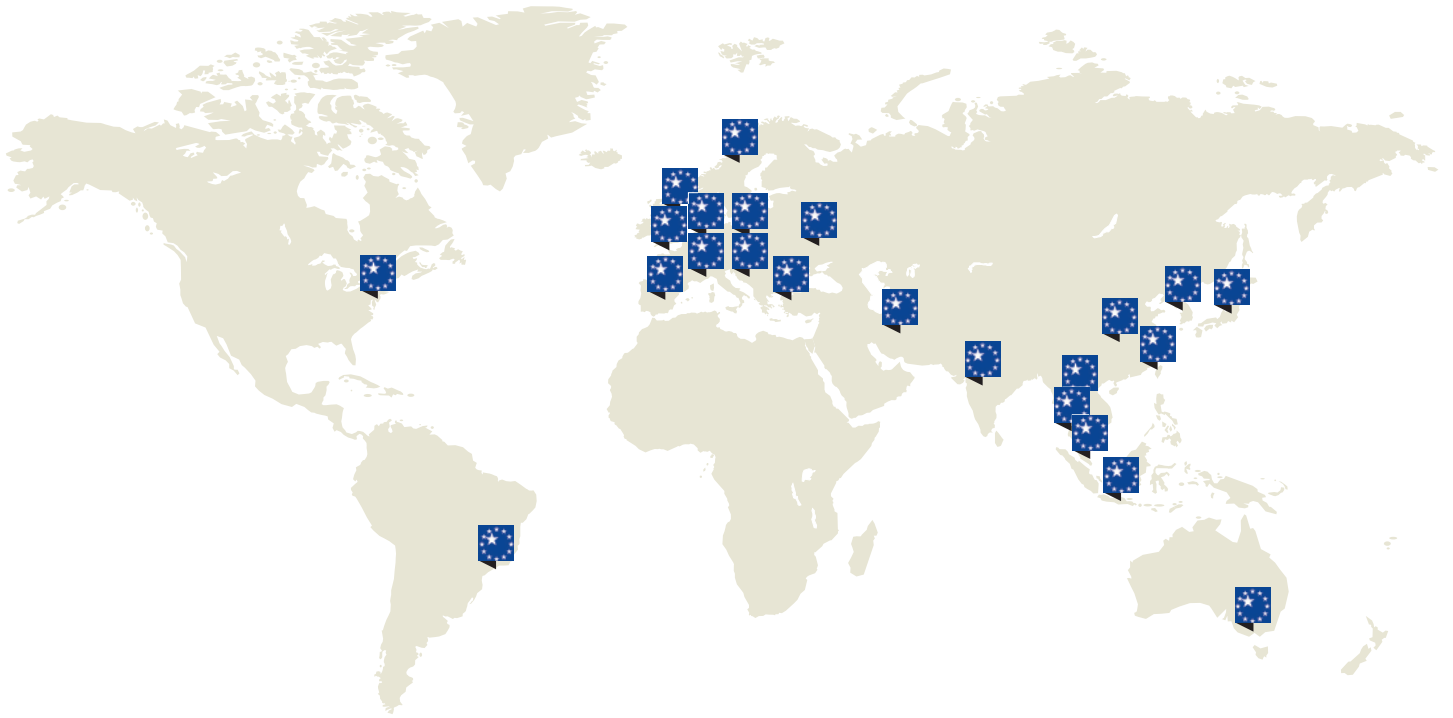

APEX is with 29 offices present in 25 countries worldwide!

---

## Contact

Apex Dynamics BV  
Churchillaan 101  
NL-5705 BK Helmond

Netherlands	Telefoon	:	+31 (0)492 509 995
	e-mail	:	sales@apexdyna.nl
	website	:	www.apexdyna.nl

Belgium	Telefoon	:	+32 (0)3 808 15 62
	e-mail	:	sales@apexdyna.be
	website	:	www.apexdyna.be